

Nilfisk Ride-on Combination Machines

Nilfisk ER 1300/1600

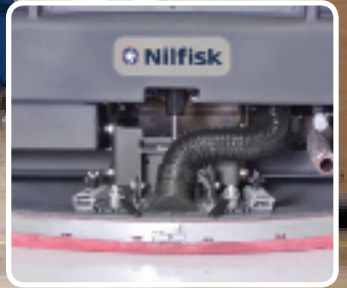

Bigger cleaning capacity – Higher productivity



The ER 1300/1600 ride-on combination machines are the definition of innovative and optimized design. This manoeuvrable front steer is the widest cylindrical scrub deck in its class. This deck's dual counter-rotating cylindrical brushes are capable of sweeping and scrubbing in one single pass.

Two different cleaning systems available in all the engine versions allow you to customize the ER 1300/1600 to your facility's needs. Cleaning paths up to 157 cm are available on the machines. This coupled with efficiently packaged 380 litre solution tank delivers the capability of cleaning up to 13.900 m²/h.

With ER 1300/1600 on-board EDS - ECO Dosage Solution system, productivity and chemical savings are maximized. The ER 1300/1600 design has set the standard in productivity, serviceability, safety and ease of use.

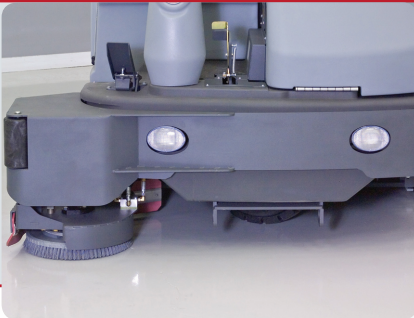

ER 1600 (right scrub unit)



ER 1300 (dual sweep)



DustGuard™ suppresses airborne fugitive dust allowing continuous use



Ideal applications include: distribution centers, manufacturing plants, parking lots, warehouse and other large cleaning applications

More mobility for better cleaning performance

- OneTouch™ control panel, Front Steering system & ClearView™ sight lines
- 380 solution & recovery tanks, 42 l vacuumized hopper
- Tip out recovery tank opening with debris tray (std)
- MaxAccess™: Full access to the machine for service
- DustGuard™ and EDS for maximum machine efficiency and productivity
- NoTool™ squeeze blades, side blades and brushes replacement and adjustment



The on-board EDS - ECO Dosage Solution system provides productivity and savings through accurate dispensing

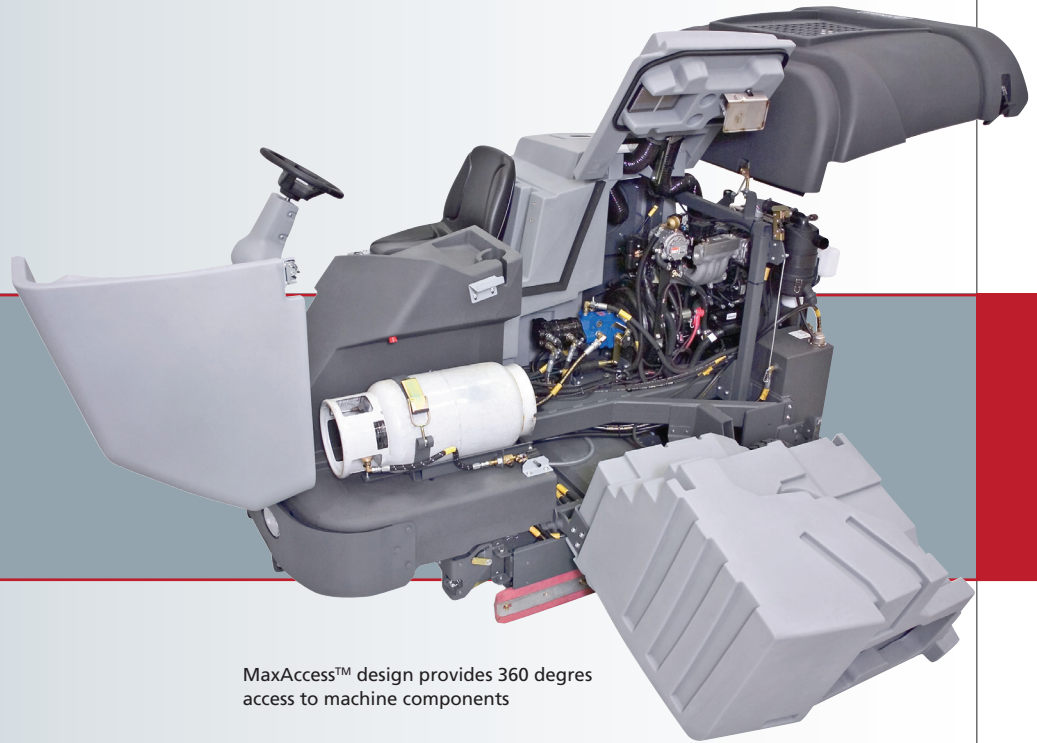

MaxAccess™ design provides 360 degrees access to machine components



The Clear-View™ design provides excellent sight lines to the floor from the comfort and safety of the operator's seat

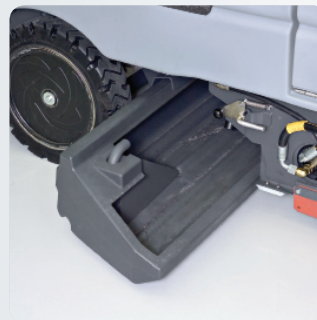

Corrosion resistant hopper slides out easily for maintenance

Serious cleaning demands a truly professional machine

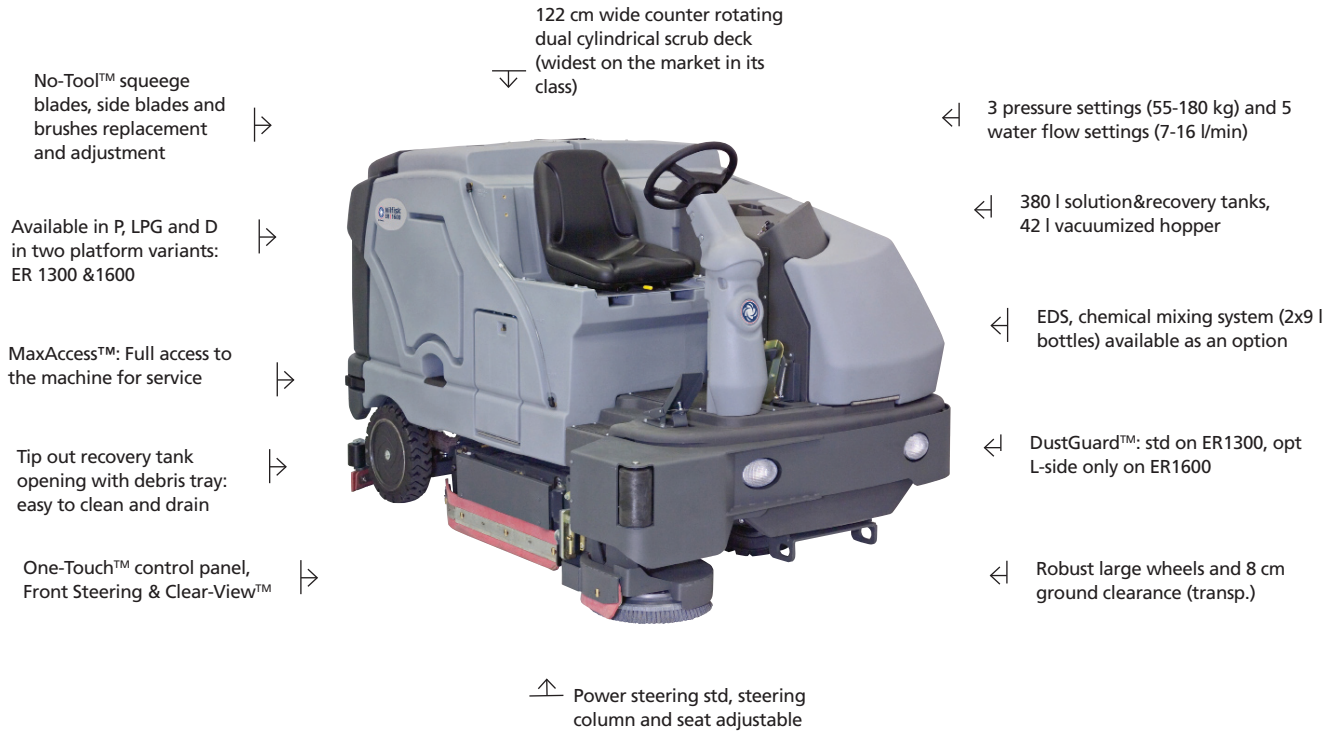

Technical specifications

Description	Unit	ER 1300 LPG	ER 1300 P	ER 1300 D	ER 1600 LPG	ER 1600 P	ER 1600 D
Motor type		4 cyl. 55 Hp, 1.6L	4 cyl. 55 Hp, 1.6L	4 cyl. 37.5 Hp, 1.5L	4 cyl. 55 Hp, 1.6L	4 cyl. 55 Hp, 1.6L	4 cyl. 37.5 Hp, 1.5L
Productivity rate theoretical/actual	m ² /h	16000/11100	16000/11100	16000/11100	19800/13900	19800/13900	19800/13900
Sweeping width	mm	1570	1570	1570	1520	1520	1520
Scrubbing width	mm	1220	1220	1220	1520	1520	1520
Min. turn around aisle width	cm	302	302	302	320	320	320
Max. speed	km/h	13	13	13	13	13	13
Solution/recovery tank	litre	380/380	380/380	380/380	380/380	380/380	380/380
Hopper volume	litre	42	42	42	42	42	42
Brush/pad qty.		2 cyl.	2 cyl.	2 cyl.	2 cyl.	2 cyl.	2 cyl.
Brush/pad pressure	kg	55/110/180	55/110/180	55/110/180	55/110/180	55/110/180	55/110/180
Length x width x height	cm	254x142x147	254x142x147	254x142x147	254x167x147	254x167x147	254x167x147
Operating weight	kg	1730	1730	1730	1834	1834	1834

CE Specifications and details are subject to change without prior notice.



Nilfisk-Advance A/S
 Sognevej 25
 DK-2605 Brøndby
 Denmark
 Tel.: +45 43 23 81 00
 Fax: +45 43 43 77 00
 mail.com@nilfisk-advance.com
 www.nilfisk.com