



VACUUMING
IN MECHANICAL PRODUCTION



INDUSTRIAL
VACUUM SOLUTIONS



Nilfisk

trusted since 1906



INDUSTRIAL VACUUMS FOR MECHANICAL PRODUCTION

How to increase savings, cleanliness and product quality in mechanical production.

Industrial vacuums are the perfect complement to mechanical production – they allow maintenance to be performed on machine tools, allowing time and resources to be saved.

This publication describes the most common solutions offered by industrial vacuums in mechanical production environments.

Just contact us to ask an expert for more details on anything in this publication, or else visit our website: industrial-vacuum.nilfisk.com.

Nilfisk has been a world leader in the manufacture of industrial vacuums for over 100 years and has a worldwide presence.

FEATURES OF AN INDUSTRIAL VACUUM FOR USE IN MECHANICAL PRODUCTION

AN ENORMOUS RANGE TO SUIT ANY SIZE AND TYPE OF COMPANY.

The range of industrial vacuums for mechanical production is enormous and meets the varied usage requirements directly expressed by manufacturing companies: single-phase, three-phase and compressed-air vacuums are all part of the huge choice.



THE SINGLE-PHASE VACUUM

If we analyse a base model single-phase vacuum from the range (see model S3B in figure 1) we can see its features designed to allow intensive use:

- Suction below the filter
- The large, removable container
- Powerful motors for vacuuming solids and liquids
- The all-metal structure, resistant to abrasive agents.

THE THREE-PHASE VACUUM

Three-phase models, in addition to the characteristics seen above, can remain on, operating continuously 24/7, as well as offering greater suction power.

THE VACUUM FOR OIL

For vacuuming 60% oil and 40% shavings. The vacuums from the OIL and VHO lines represent the tools giving the greatest ROI in terms of oil and time savings. See the OIL range in action: **on our website.**

Manual filter shaker

70mm inlet diameter

50 or 100 L container

Wheels on the container



Motor head with single-phase bypass motor

Class L star filter

Container release system

Manual filter shaker

HEPA filter

Plug with phase inverter

50 or 100 L container

Container with integrated wheels and handle



Class L or M star filter

Handle for easy manoeuvring of the machine

Pressure gauge to check filtering efficiency

Side blower from 2.2 up to 22 kW

Automatic liquid stop

Gun for reintroduction of liquids

Accessory holder

Pump for expulsion of liquids

Anti-oil rear wheels with brake



Quick fitting with 360° rotating suction curved connection

Automatic liquid stop

Tube-cable holder

Liquid containers from 100 to 675 litres

Basket for recovery of metal shavings, complete with lifting belt



USING INDUSTRIAL VACUUMS
CAN SAVE YOU UP TO 200 HOURS
OF MACHINERY DOWNTIME
PER YEAR

”



VACUUMING SHAVINGS AND OIL

REDUCING MACHINE DOWNTIME

The industrial vacuum is the most appropriate tool for removing metal shavings from machine tools after each work cycle. This operation keeps machinery in perfect working order, reduces downtime and guarantees maximum product quality.

”Maximum product quality ...”
Nilfisk industrial vacuums are used to clean products immediately after working in order to reveal any imperfections and avoid further abrasions due to the presence of micro-particles of metal on the surface of the piece “



USING THE OIL SERIES MEANS SAVING
AROUND 5 HOURS EACH TIME
THE TANK IS CLEANED

”



SEPARATION OF SHAVINGS FROM OIL

INCREASE PRODUCTION BY AVOIDING WASTED OIL

The industrial vacuums in the "OIL" series can vacuum up cutting oil and emulsion at the same time as shavings. The solid and liquid components are separated via "macro-filtration", allowing the emulsion to be reused. Regular use of vacuums from the OIL series not only performs maintenance of the machine tools but also means great economic savings.

”Vacuuming cutting oil and emulsion together with the shavings ...”
The OIL series prevents the formation of bacteria and mould and prolongs the use of any type of emulsion “



WITH NILFISK LIQUID VACUUMS, 100
LITRES OF LIQUIDS CAN BE VACUUMED
AND FILTERED IN A FEW SECONDS

”



VACUUMING OF LIQUIDS

INCREASE EFFICIENCY IN AN ENVIRONMENT WHICH IS ALWAYS CLEAN

In any mechanical production company it will be constantly necessary to vacuum oil, emulsions, chemical solutions and water. Vacuuming of liquids represents a saving in the case that the emulsion is to be filtered and reused, but also because the time dedicated to cleaning and maintaining the machinery and the surrounding areas is reduced. For these operations, Nilfisk has produced the VHO series which, as well as performing suction and micro-filtration of solids and liquids, allows the liquid to be expelled at pressure, facilitating storage of liquids in drums or simply its disposal in the appropriate places.

” Vacuuming up the liquids represents a saving ...”
So much liquid is wasted due to the absence of an industrial vacuum “



THE DUAL BENEFIT OF ELIMINATING
ENVIRONMENTAL DUST AND
RECOVERING WASTE

”



VACUUMING GRAPHITE POWDER

REACHING TOTAL PRODUCT QUALITY WHILE PROTECTING HEALTH

Nilfisk has dedicated solutions for those producing refractory materials, lubricants, pencils, colourings, electrodes and moulds for reactive metals, all products manufactured with or containing graphite. Industrial vacuums have the function of continuously vacuuming the high quantity of powders and waste material produced inside the milling cutters by their operation. Using a Nilfisk vacuum guarantees high product quality as in this way it is not "contaminated" by production waste, as well as ensuring perfect maintenance of the milling cutter and a healthy, dust-free environment.

”Guarantees high product quality...”
Given the high cost of production, the guarantee of obtaining a perfect product from milling is essential



ELIMINATES COMBUSTION RISKS,

INCREASING SAFETY IN YOUR

WORKPLACE

”



VACUUMING OF PLASTIC MATERIAL, MAGNESIUM, ALUMINIUM, LITHIUM AND SODIUM POWDERS

SAFETY ABOVE ALL ELSE

The materials listed above represent a danger as they can burn or explode if ignited. Nilfisk manufactures both electric and compressed-air vacuums which are ATEX certified, able to operate in the presence of these materials without causing sources of ignition. The vacuums can be used in ATEX zones 1, 2, 21 and 22. Visit our website to find out all about the ATEX line: industrial-vacuum.nilfisk.com.

” Produces ATEX-certified industrial vacuums ... ”
The safety offered by industrial vacuum cleaners Nilfisk has been certified by international certification bodies “



SAVE THOUSANDS OF EUROS
A YEAR WHILE INCREASING
PRODUCT QUALITY

”



SUCTION OF BRASS AND PRECIOUS METAL SHAVINGS

MAKE SAVINGS WITH A FEW SMALL ACTS

Nilfisk offers the ideal solution for vacuuming precious metals in order to recover every single shaving or speck of metal while it is being machined. Companies which use Nilfisk vacuums are able to recover every single particle of metal which is sucked up thanks to the dedicated filters present – in this way, the investment in the vacuum is paid back very quickly.

”Recover every single particle...”
The savings offered by Nilfisk vacuums are immediate, guaranteeing optimisation of the production process



MAKE THE MOST DIFFICULT

CLEANING JOBS QUICK AND EASY

”



VACUUMING GRINDING SLUDGE

POWER MEETS CLEANING

Vacuuming grinding sludge is quick and easy with Nilfisk. The powerful vacuum suction offered by the three-phase models allows vacuuming of the heaviest sludge; the tubes used have no resistance, allowing all the suction power to be used.

”Vacuum up the heaviest sludge...”
Quick and easy maintenance of workstations and machine tools is the first step towards efficiency, product and environmental quality and safety

OPTIONAL

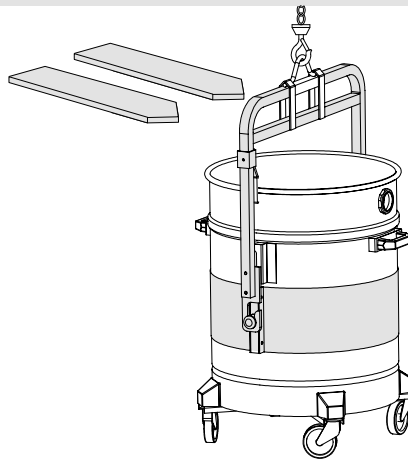

Clamp and bracket

Used for transporting and emptying the container with a forklift, or hook and chain. The clamp can be left on the container. The bracket is only used for moving and emptying.

Separator

Used for protecting the primary filter from splashes of liquids or potentially sharp material which is being vacuumed.

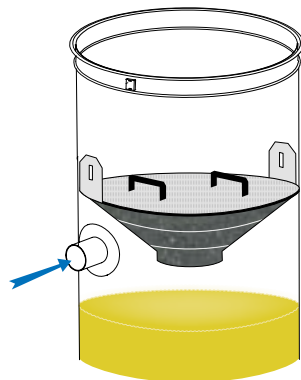
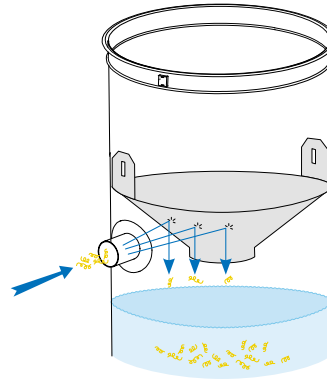

Removable separator for oil fogs

Protects the filter from oil fogs, remaining effective over time.

Grille and valve

Ideal for separating solid material from liquids directly inside the container. The grille in the base of the container lets solid material deposit, while liquids can be recovered or drained through the manual valve on the bottom.

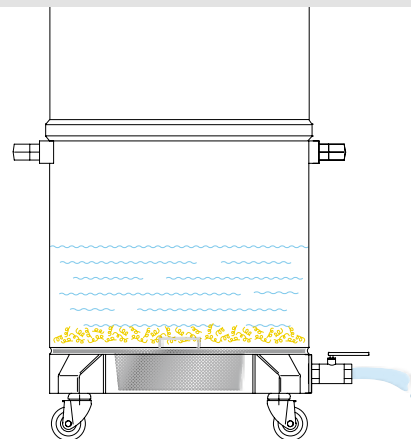

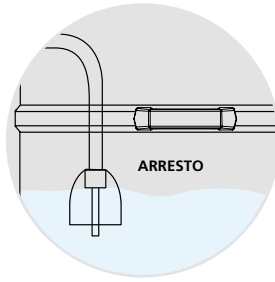
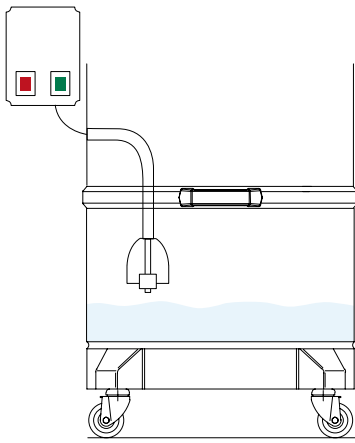

Automatic liquid stop

Necessary when you want to vacuum liquids and have suction be cut off when the maximum liquid level inside the container is reached.

Mechanical liquid stop

Ideal for vacuuming liquids. On reaching the maximum liquid level in the container, the rising float comes to block the passage of air, drastically reducing suction.

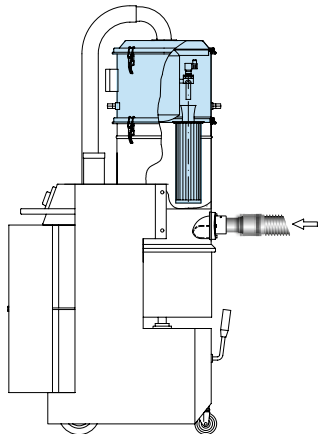
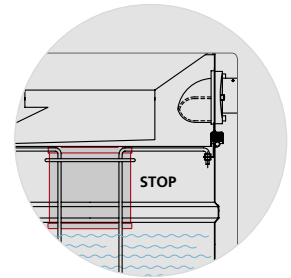
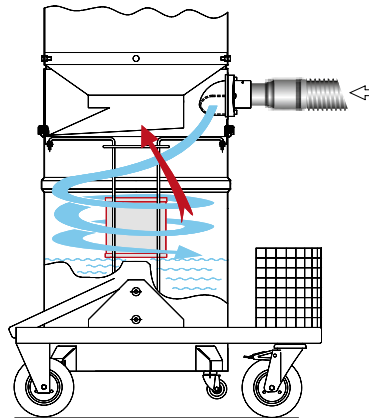

Cartridge kit

Allows automatic cleaning of the cartridge while vacuuming very fine and dry powders. The system works continuously, allowing filtering efficiency to be maintained without having to switch off the vacuum to clean the filter.

Integrated outlet

Ideal for discharging vacuumed material into pits or onto conveyor belts. The material is discharged by gravity when the vacuuming stops.

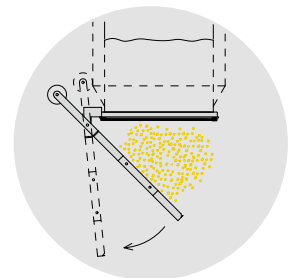
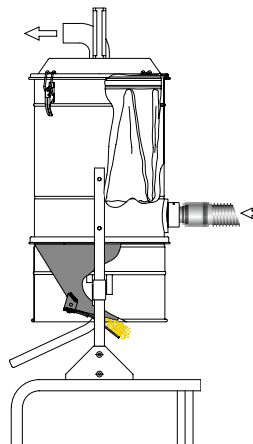

OPTIONAL

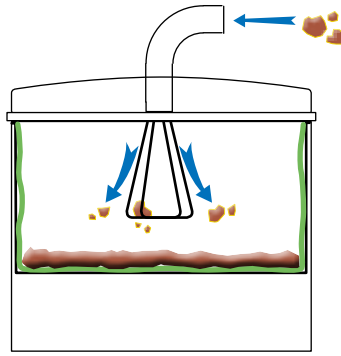

Sludge filter kit

Ideal for separation of vacuumed sludge and liquids. Located inside the mesh basket. Filtration grade 50/100 or 300 micron (for the OIL series).

Shavings basket

Indispensable for collecting and separating shavings from liquids (50/50) and then transporting and emptying them using a forklift, tackle or other chain system.

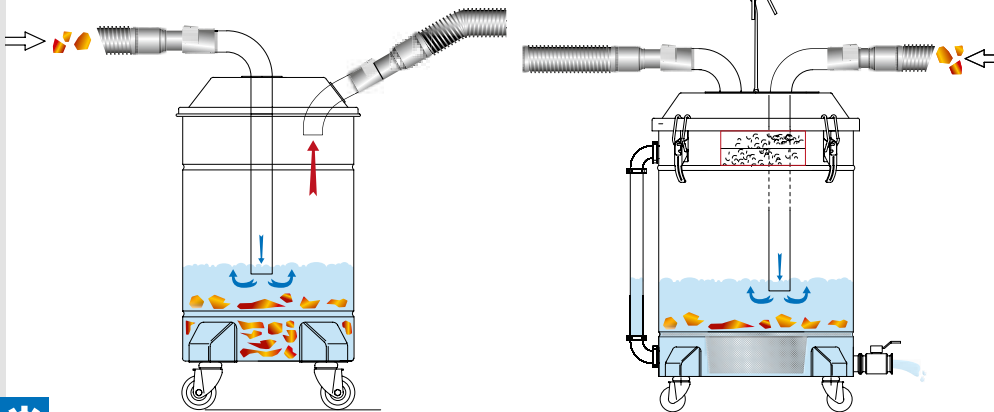
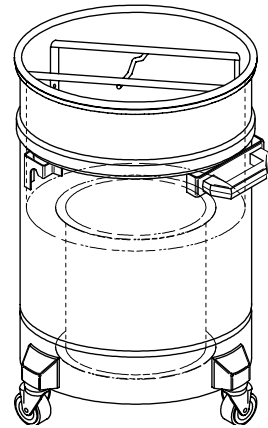
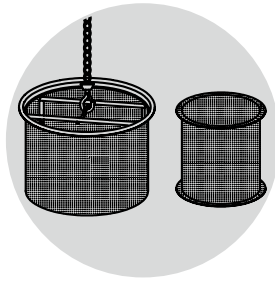

Separator for white-hot substances

Ideal for vacuuming and collecting white-hot substances. The material is cooled when it comes into contact with the water in the container. This system is also suitable for use with fine (powder) material.

Special separator for liquids

Ideal for vacuuming and collecting liquids. Grilles inside the tank separate the debris or shavings from the liquid, which can then be drained.

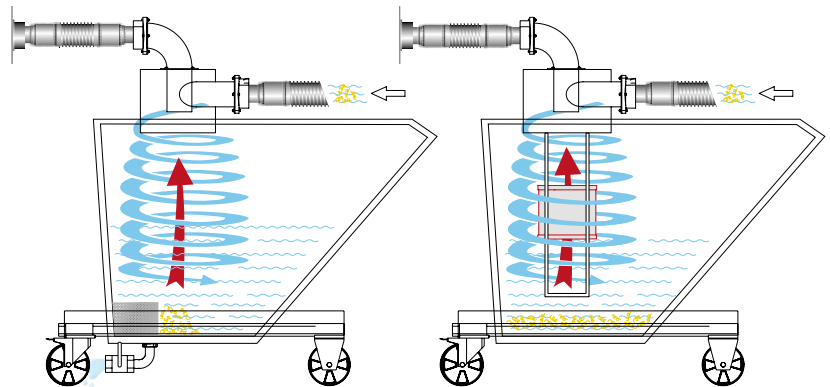

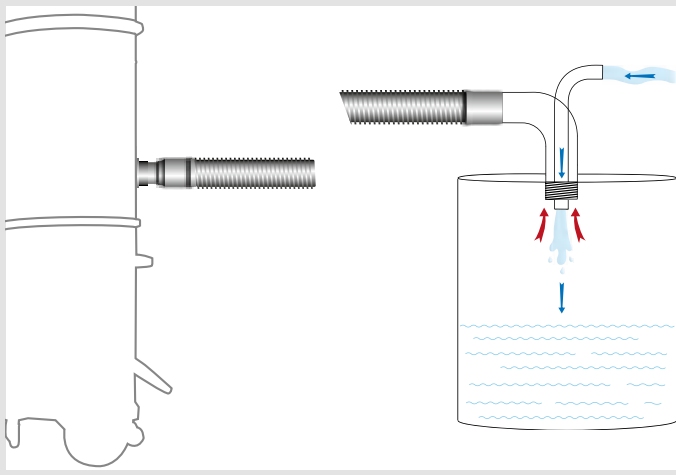

Double intake fitting

Ideal for application on 200 L oil drum. The fitting screws onto the cover so you can fill the drum with the vacuumed liquid.

Tilting separator

Ideal for vacuuming and collecting large amounts of material. Prevents the vacuum cleaner container filling too often, causing frequent interruptions in the work cycle. Easy to move with a forklift and easy to empty. Generally used with medium- or high-powered machines.

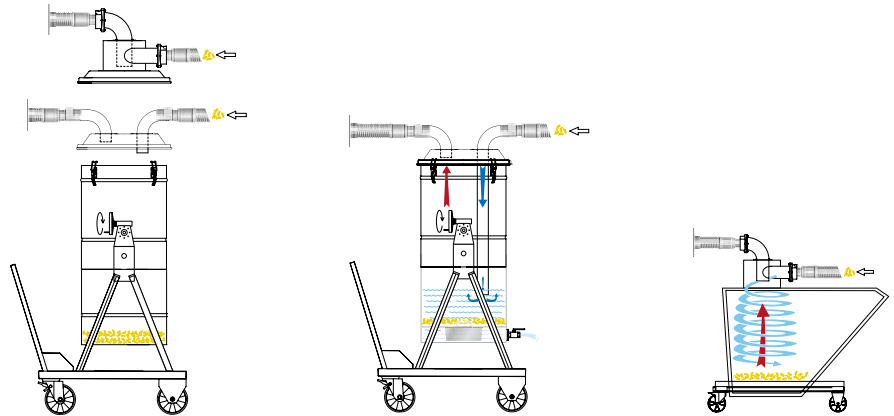

Industrial cleaning accessory kit

The industrial cleaning accessory kit is ideal whenever it is necessary to clean large areas. Composed of:

- Zinc-plated reduction
- 3m Polyurethane hose with sleeves
- Chromed hand grip
- Rubber cone
- Round brush with
- Nylon bristles
- Wheeled floor nozzle for dust and liquids
- Zinc-plated flat-tip crevice nozzle
- Zinc-plated junction fitting

The kit allows quick and effective cleaning of the relevant area. It is available in two sizes: 40mm and 50mm diameter.



Oil-proof Accessories Kit

This kit has been designed to resist corrosion caused by oil and emulsions:

- 3m rubber hose with sleeves
- Zinc-plated junction fitting
- Rubber cone
- Chromed hand grip
- Wheeled floor nozzle for dust and liquids
- Zinc-plated reduction

It is available in two sizes: 40mm and 50mm diameter.

INDUSTRIAL
VACUUM SOLUTIONS

